

# MMS 6312

## Dual Channel Rotational Speed Monitor

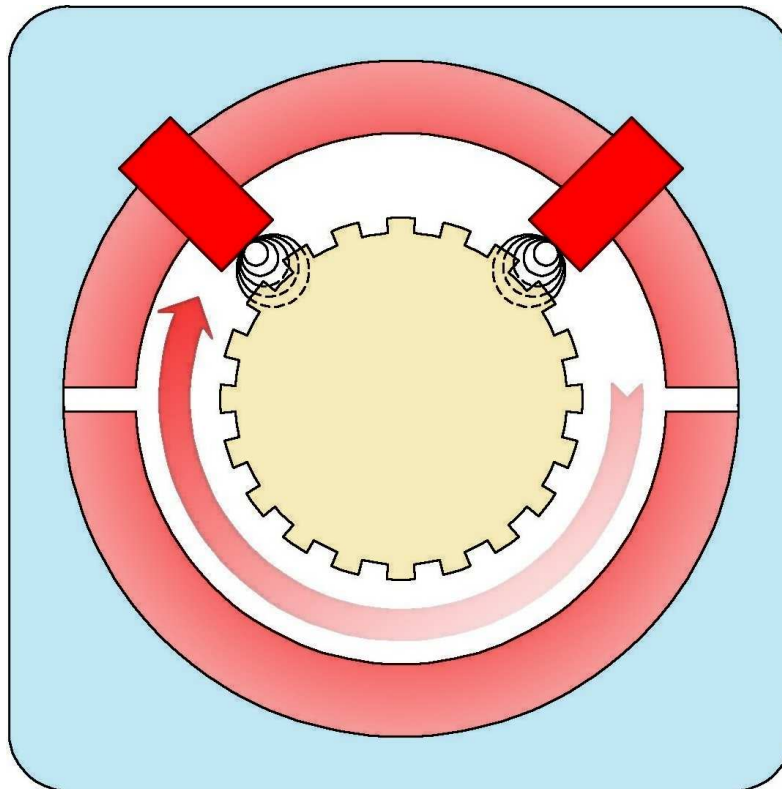

- Part of the MMS 6000 System
- Replaceable during operation; stand alone use possible, redundant supply inputs
- Extended self-checking facilities; built in sensor-self-test facilities;
- For use with eddy-current type transducer systems PR 6422/.. to PR 6425/.. with CON 0.. or with PR 9376/.. and PR 6453/.. pulse sensors
- Galvanically separated current outputs
- RS 232 interface for local configuration and readout
- RS 485 interface for communication with epro's Analysis and Diagnostic System MMS 6850

### Applications:

The **Dual Channel Rotational Speed Measuring Module MMS 6312** measures shaft speeds – using outputs from pulse sensors in combination with triggering wheels. Both channels may be separately used to measure:

- 2 speeds from 2 shafts
- 2 standstills from 2 shafts
- 2 key-pulses from 2 shafts with each one triggermark (with phase relation)

Both channels may also be used in combination with each other:

- to detect the direction of rotation of one shaft
- to detect a difference between two shaft speeds
- as part of multichannel or redundant systems

requested by Analysis and Diagnostic Systems, Field Bus Systems, Distributed Control Systems, plant/host computers and networks as e. g. WAN/LAN, Ethernet. Such Systems are also suitable to build up systems to increase the performance and efficiency, the safety of operation and extend the lifetime of machines such as steam-gas-hydro turbines as well as compressors, fans, centrifuges and other turbomachines.

## Technical data:

### Sensor inputs:

Two independent differential inputs for pulse sensors such as **epro's** eddy-current type sensor systems PR 6422/.. to PR 6425/.. with CON 0.. or PR 9376/.. or PR 6453/.. or any other sensor system with matching specification.

Input resistance:

> 100 kOhm

Input voltage range :

0...+ or -27.3 V dc

Max. permissible input voltage range:

0...30 V

Input frequency range:

0...20000 Hz

Automatic or manual trigger level adjustment:

Minimum input level for automatic tracing: 2 V

### Available sensor supply:

For each of the two sensor input channels a separate buffered sensor supply voltage is available.

These outputs are galvanically separated from all system voltages as well as from the system supply voltage and are open – and short circuit proofed and may be operated in parallel with other modules without interference.

Nominal voltage:

+ or -26.75 V dc

Available current:

nom. 20 mA / max. 35 mA

### Measuring ranges:

Continuously configurable with the configuration software:

input frequency range:

0...20 kHz configurable to max. 65535 RPM

### Control inputs:

Common logic binary input for both channels to reset latched alarms Logic binary input to select the output optocoupler mode:

"Out 1-1"; make or brake

"Out 2-1"; make or brake

logic binary input to inhibit the alarms

24 V logic

Input resistance:

>10 kOhm

## Measuring modes:

Each channel can and must be individually configured with the relevant configuration software. Measuring modes can be configured via an externally connected laptop (RS 232 connector on the frontpanel of the module) or via the RS 485 communication bus. Measuring modes can be changed at any time during operation.

### Available operating and measuring modes:

#### Speed measurement with each channel:

Forward or backwards speed measurement with pulse sensors / trigger wheels with 1 to 255 trigger marks and a frequency of max. 20 kHz.

Measures pulses within a time window of 5 to 10 ms with a reaction time of 26 ms or number of pulses during part of a revolution or max. 1 revolution (automatic tracking),

or measures and processes speed from number of pulses per one revolution

output: analogue output proportional to the speed,

or analogue output with splitted range (different sensitivities for different parts of the range),

or analogue output with enlarged range (higher sensitivity for only a part of the total range) and standard rectangular TTL pulses,

or speed measurements with redundant transducers (1 out of two) with both channels for one measurement.

#### Key-pulse detection with each channel:

Either with one key mark on the shaft (with defined phase relation) or with multiple key marks with max. 255 marks per revolution,

output: standard negative or positive rectangular key puls of 1 ms duration

#### Standstill detection with each channel:

Detects standstill of trigger wheels with 1 to 255 trigger marks:

Measures time between two pulses in a configurable range of 1 to 1700 s;

backwards/forwards detection.

### Both channels in combined use:

Detects the direction of a rotation with two trigger marks of which one is phase-shifted.

### Detects a difference between the speed of two trigger wheels:

Difference adjustable in number of RPM

## Limit supervision:

For each channel two separately adjustable alarm levels are available which can be operated in the following different modes:

increasing or decreasing measuring level; with or without latching.

If the complete module is used in a single channel or if both channels are

used in a combined mode all available 4 alarm outputs may be used with that channel.

The alarm output functions can be blocked by the channel clear / circuit fault function or by an external input.

Adjustable ranges:

5...100 % fsd.

Resolution and reproducibility:

1 ‰ of fsd

Delay time:

configurable between 0...25.5 s

Switching hysteresis:

configurable

Outputs: via galvanically separated, potential free optocouplers on the rear strip connector.

## Module and sensor supervision:

<p>The internal module supervision circuitry continuously supervises the following functions:</p> <p>input signal is within a preset window.</p> <p>Cabling between sensor and module is ok (no shortcircuit, no break ).</p> <p>For PR 9376/.. transducers only short circuits and cable breaks can be detected.</p>	<p>System supply voltages are within preset windows.</p> <p>Configuration and parameter settings are correct.</p> <p>Manual and automatic trigger level set-up System watch dog.</p> <p>"Channel clear" is visualised on the front of the module by means of a green LED; this LED switches off during a "channel fault".</p> <p>The channel status is also indicated via a</p>	<p>binary output, separately for each of the two channels.</p> <p><math>U_{max} = 48 \text{ V dc}</math></p> <p><math>I_{max} = 100 \text{ mA}</math></p> <p>The reasons for a "channel fault" indication can be read out via the communication buses; which enables service personnel to take immediate corrective measures.</p>
---	---	---

## Signal outputs at the connecting strip:

<p>Terminal strip on rear side: acc. to DIN 41 612 , version F 48 M</p> <p><b>RS 485 communication interface.</b></p> <p><b>Two independent pulse outputs:</b> One for each channel; rectangular, pulses identical to the input pulse rate.</p> <p>Frequency range: 0...20 kHz</p>	<p><b>Two independent pulse outputs:</b> One for each channel; rectangular, inverted pulses identical to the input pulse rate,</p> <p>0...+5 V (TTL), open and shortcircuit proof Load resistance: &gt; 10 kOhm Frequency range: 0...20 kHz</p>	<p><b>Two independent analogue current outputs:</b> One for each channel; outputs are proportional to the selected measuring range and mode and galvanically separated.</p> <p>0/4...20 mA; configurable, open- and shortcircuit proof Permissible load: 500 Ohms Accuracy: 16 bit resolution ; <math>\pm 1 \%</math> of full scale Range</p>
--	---	---

## Operating elements at the module front:

<p><b>Two independent input pulse sockets:</b> identical to the transducer pulse input rate, available via SMB sockets; one for each channel.</p> <p>Range: 0...4.096 V (reduced by a factor of 0.15)</p> <p>Load: &gt;10 kOhm</p> <p>Frequency range: 0...20 kHz</p>	<p>input rate identical to the transducer, available via SMB sockets; one for each channel.</p> <p>Range: 0...+5 V (TTL), open and short-circuit proof</p> <p>Load: &gt;10 kOhm</p> <p>Frequency range: 0...20 kHz</p>	<p><b>4 yellow LED`s:</b> Indicate the status of the 4 limit outputs.</p> <p><b>1 Mini-DIN diode type socket:</b> as input for the configuration cable RS 232 communication interface.</p> <p><b>Handle:</b> To pull out or insert module with identification labelling facility.</p>
<p><b>Two independent output pulse sockets:</b> Standard, rectangular TTL Pulse; pulse</p>	<p><b>2 green LED`s:</b> Indicate "channel clear" separately for channel 1 and channel 2.</p>	

## Power supply:

Redundant supply input via two supply inputs, decoupled via diodes. At least one supply input is required for the supply of the module.

### Supply voltage:

18...24...31.2 V DC  
according to IEC 654-2, class DC4

### Power consumption:

max. 6 W (max. 250 mA at 24 V)

Other supply voltages can be realized with additional system power supplies.

## System design:

At standalone operation, unlimited number of modules.

Max. 31 modules / 62 channels may be operated at one RS 485 bus

If more modules / channels are necessary, e.g. with an MMS 6815, another RS 485 bus must be installed.

## Environmental conditions:

### Protection class:

Module: IP 00 according to DIN 40050  
Front plate: IP21 according to DIN 40050

### Climate conditions:

according to DIN 40040 class KTF  
operating temperature range:  
0...+65°C

### Temperature range for storage and transport:

-30...+85°C

### Permissible relative humidity:

5...95%, non condensing

### Permissible vibration:

according to IEC 68-2, part 6

### Vibration amplitude:

0.15 mm in range 10...55 Hz

### Vibration acceleration:

16.6 m/s<sup>2</sup> in range 55...150Hz

### Permissible shock:

according to IEC 68-2, part 29  
peak value of acceleration:

98 m/s<sup>2</sup>

nominal shock duration:

16 ms

### EMC resistance:

according to EN50081-1 / EN50082-2

**Dimensions:**

PCB/EURO card format acc. to  
 DIN 41494 (100 x 160 mm)  
 Width: 30,0 mm (6 TE)  
 Height: 128,4 mm (3 HE)  
 Length: 160,0 mm  
 Net weight: app. 320 g  
 Gross weight: app. 450 g  
 incl. standard export packing  
 Packing volume: app. 2,5 dm<sup>3</sup>  
 Space requirements:  
 14 modules (28 channels) fit into each  
 19" rack

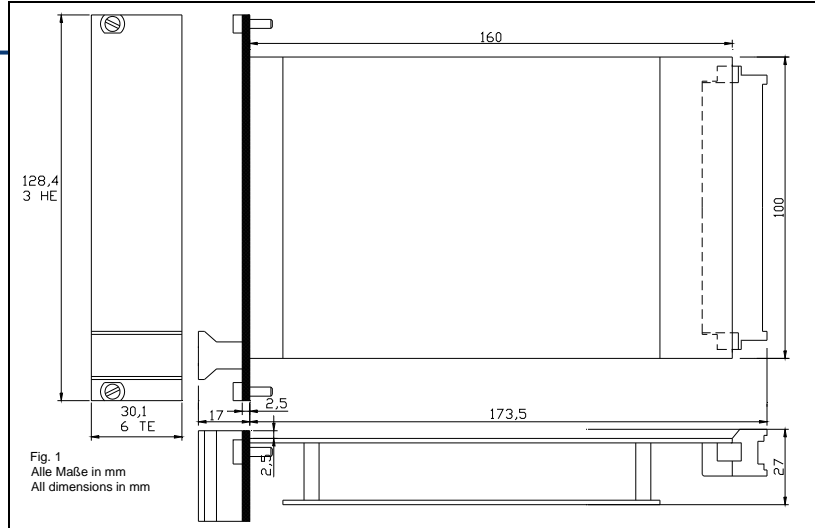

**Requirements on configuration PC:**

Configuration of modules is made via the RS 232 interface on the module front or via the RS 485 bus by means of a computer (laptop) with the following minimum specifications:

**Processor:**  
 486 DX, 33 MHz  
**Interfaces:**  
 one free RS 232 interface (COM 1 or COM 2) with FIFO type 156550 UART

**Capacity of fixed disk:**  
 min. 5 MB  
**Required working memory:**  
 min. 620 KB  
**Operating system:**  
 MS DOS Version 6.22 or higher or WIN® 95/98 or NT 4.0

**Connection diagram:**

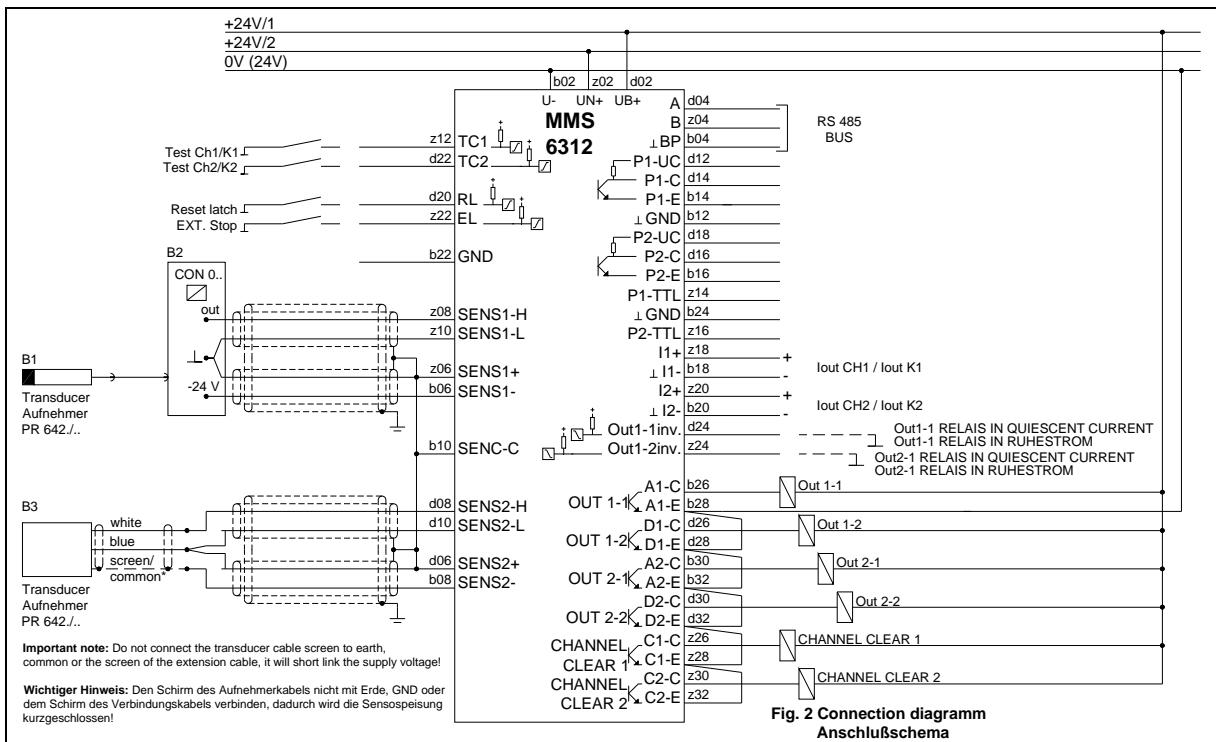

**Order number:**

<b>MMS 6312</b>	Dual Channel Rotational Speed Monitor.....	<b>9100 – 00025</b>
<b>MMS 6910 W</b>	Operating accessories .....	<b>9510 – 00017</b>
	consisting of: operating and installation manual, configuration software and various connection cables	

The F48M mating connector has to be ordered separately depending on the intended wiring technology.



**6010 – 00022 07/05 Reh**  
 Printed in Germany. Due to continued research and product development epro reserves the right to change these specifications without notice.